

MODELS

JS42, JS43, JS63, JS83 (STYLE E – SHORT STROKE)

JS44, JS64, JS84 (STYLE E – LONG STROKE)

JS43, JS63, JS83 (STYLE F – SHORT STROKE)

JS44, JS64, JS84 (STYLE F – LONG STROKE)

NOMENCLATURE

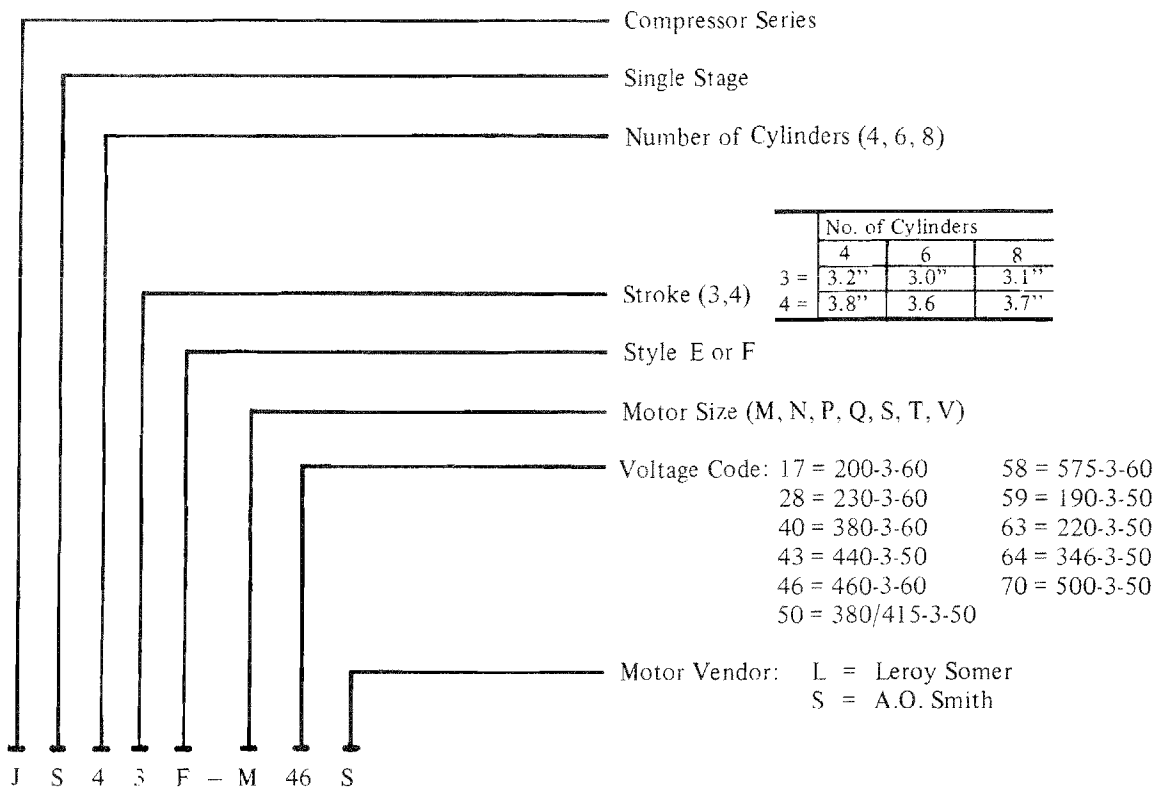

ORDERING INSTRUCTIONS

1. Locate compressor model number from data plate on pump end of compressor.
2. When ordering renewal parts, identify each part by part number obtained from Tables. Also include required quantity and compressor model number. Parts are common for Styles E and F except where noted.
3. Read carefully any explanatory notes accompanying tables.
4. The symbol (S) preceding an item indicates recommended spare part.
5. To order parts; call 1-800-932-1701 or Fax 1-800-932-1702
6. To order York remanufactured compressors, call 1-800-537-9675. See page 11 for more details.

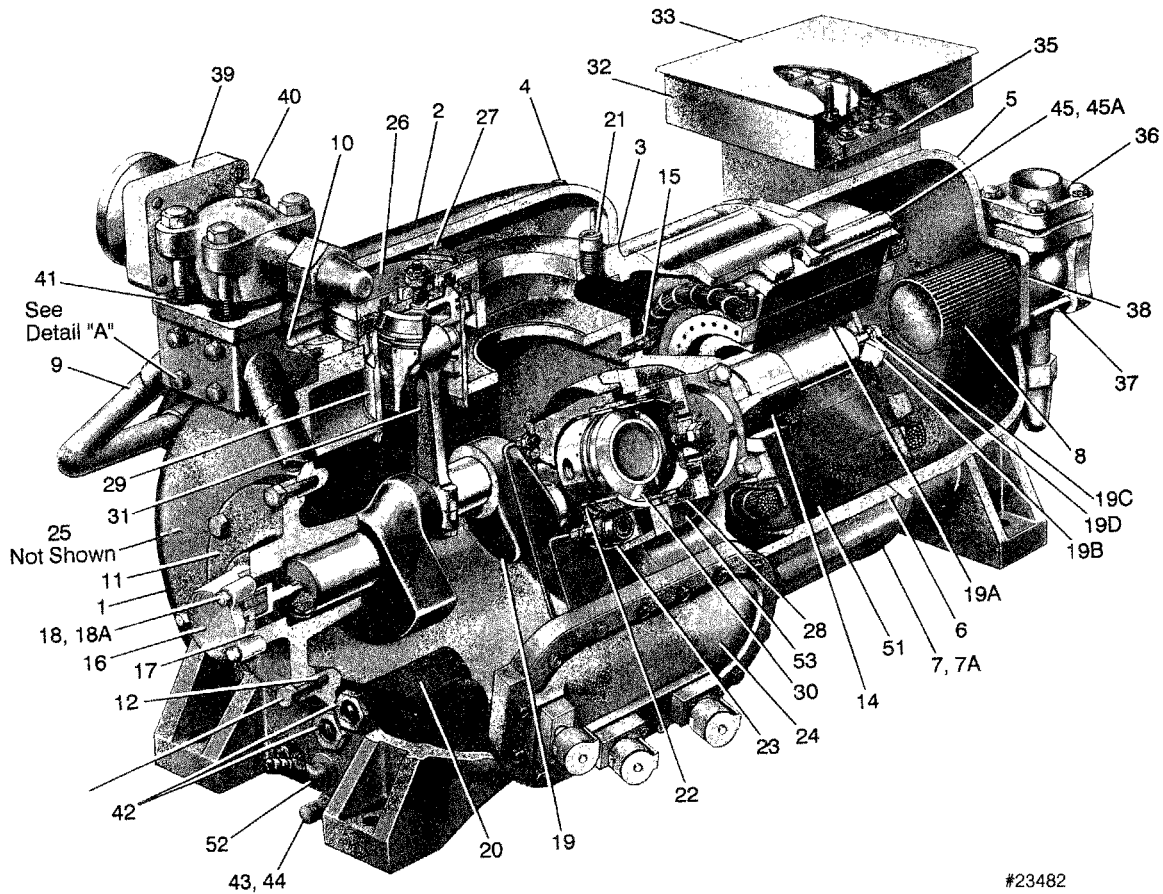
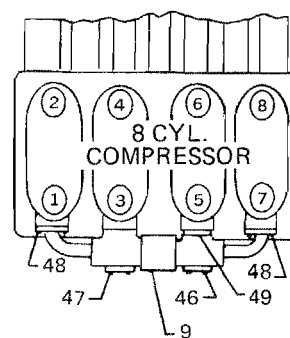
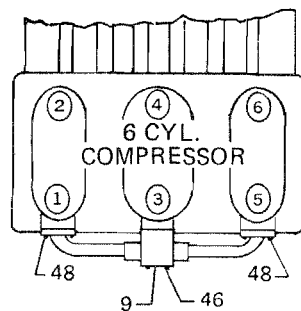
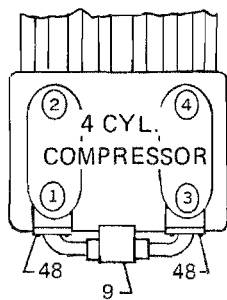

FIG. 1 – COMPRESSOR CUT-A-WAY

DETAIL "A" – MANIFOLD ARRANGEMENTS



ITEM NO.	DESCRIPTION	COMPRESSOR MODEL		
		4 Cyl.	6 Cyl.	8 Cyl.
1	Housing, Compressor	664-47309	664-47310	664-47311
2	Head, Compressor No. Req'd. Per Compressor	664-21612 2	664-21612 3	664-21612 4
3	Gasket, Head No. Req'd. Per Compressor	064-21700 2	064-21700 3	064-21700 4
4	Screw, Head 7/16 - 14 x 4 No. Req'd. Per Compressor	021-16816 32	021-16816 48	021-16816 64
5	Cover, Motor	664-47188	664-47188	664-47203
6	Gasket, Motor Cover to Compressor	064-47186	064-47186	064-47186
7	Screw, Motor Cover to Compr. 1/2 - 13 x 2-1/4 No. Req'd.	021-01586 20	021-01586 20	021-01586 20
7A	Lockwasher Spg. 1/2	221-05271-800	221-05271-800	221-05271-800
8	Screen, Suction (See Item 38 for Gasket)	026-28473	026-28473	026-28474
9	Manifold, Discharge	664-23147	664-23064	664-21709
10	Gasket, Discharge Manifold No. Req'd. Per Compressor	064-21838 2	064-21838 3	064-21838 5
11	Head, Bearing Assy. Oil Pump End	See Figure 9		

ITEM NO.	DESCRIPTION	COMPRESSOR MODEL		
		4 Cyl.	6 Cyl	8 Cyl.
12	Gasket, Bearing Head, Oil Pump End	064-21703	064-21703	064-21703
13	Screw, Bearing Head, Oil Pump End 7/16 - 14 x 1-3/4 (5/Pk'g) No. Pk'gs. Req'd. Per Compressor	221-01545-800 2	221-01545-800 2	221-01545-800 2
14	Head, Bearing Assy. Motor End	See Figure 9		
15	Screw, Bearing Head, Motor End 7/16- 14 x 1-1/2 (5/Pk'g.) No. Pk'gs. Req'd. Per Compr.	221-10387-800 1	221-10387-800 1	221-10387-800 1
⑤ 16	Pump, Oil	026-29379	026-29379	026-29379
17	Gasket, Oil Pump	064-47194	064-47194	064-47194
18	Screw, Oil Pump 1/4 - 20 x 1-1/8 No. Req'd. Per Compressor	021-16826 6	021-16826 6	021-16826 6
18A	Lockwasher Spg. 1/4 (20/Pk'g.)	221-05267-800	221-05267-800	221-05267-800
⑤ 19	Crankshaft Stroke 3	664-47209	664-47210	664-47211
	Stroke 4	664-47215	664-47216	664-47217
19A	Key, Motor	064-26560	064-26560	064-26560
19B	Washer Shaft	064-21835	064-21835	064-21835
19C	Screw Cap 5/8 - 11 x 2 (5/Pk'g.)	221-01630-800	221-01630-800	221-01630-800
19D	Lockwasher, Shaft (5/Pk'g.)	221-05295-800	221-05295-800	221-05295-800
⑤ 20	Screen, Oil Strainer	029-20032	029-20032	029-20032
⑤ 21	Valve, Relief	022-03871	022-03871	022-03871
⑤ 22	Sleeve, Unloader	See Figure 10		
⑤ 23	Device, Unloader	See Figure 10		
24	Cover, Hand hole (Assy.)	See Figure 7		
25	Cover, Hand hole (Plain)	See Figure 7		
⑤ 26	Valve Cage Assy. (Discharge)	See Figure 4A & 4B		
27	Screw, Discharge Valve Cage 3/8 - 16 x 2-5/8 No. Req'd. Per Compr. (4/cage)	021-16827 16	021-16827 24	021-16827 32
28	Plate Valve (Suction)	See Figure 5		
29	Sleeve Cylinder Assy.	See Figure 6		
⑤ 30	Piston Assembly	See Figure 2		
⑤ 31	Connecting Rod Assy.	See Figure 3		
32	Box, Terminal	See Figure 8		
33	Cover, Terminal Box			
34	Screw, Terminal Box Cover			
35	Block Terminal			
36	Valve, Suction Stop	022-02844	022-02844	022-02845
37	Screw, Cap- Suction Stop Valve (4 Req'd. Per Valve)	021-16817	021-16817	021-16818
38	Gasket Suction Valve to Motor Cover No. Req'd.	064-47079 2	064-47079 2	064-47204 2
39	Valve, Discharge Stop	022-01394	022-01394	022-02844
40	Screw, Cap-Discharge Stop (4 Req'd. Per Valve)	021-16821	021-16821	021-16817
41	Gasket, Discharge Valve To Manifold	064-47078	064-47078	064-47079
⑤ 42	Sight Glass, Oil (2 Req'd.)	026-17581	026-17581	026-17581
⑤ 43	Valve, Oil Charging	022-01582	022-01582	022-01582
44	Cap, Oil Charging Valve	023-00977	023-00977	023-00977
45	Screw, Motor to Compressor	See Table 2		
45A	Lockwasher Spg. 7/16	221-05270-800	221-05270-800	221-05270-800
46	Screw, Cap Hex 7/16 - 14 x 5 (10/Pk'g.) No. Pk'gs. Req'd. Per Compressor	— —	— —	021-10090 1
47	Screw, Cap Hex 7/16 - 14 x 4 (10/Pk'g.) No. Pk'gs. Req'd. Per Compressor	— —	— —	021-14158 1
48	Screw, Cap Hex 7/16 - 14 x 1-1/2 (5/Pk'g.) No. Pk'gs. Req'd. Per Compressor	221-10387-800 3	221-10387-800 3	221-10387-800 3
49	Spacer, Manifold (See Detail "A")	—	—	664-21756
50	Washer, Thrust*	029-11098	029-11098	029-11098
⑤ 51	Motor	See Table 1 or 2, page 11		
52	Heater Crankcase — 115V — 230V	025-10462 025-13553	025-10462 025-13553	025-10462 025-13553
53	Drain Orifice No. Req'd. Per Compressor	064-47349 1	064-47349 2	064-47349 3

*Not shown in cut-a-way. Located at motor end bearing only.

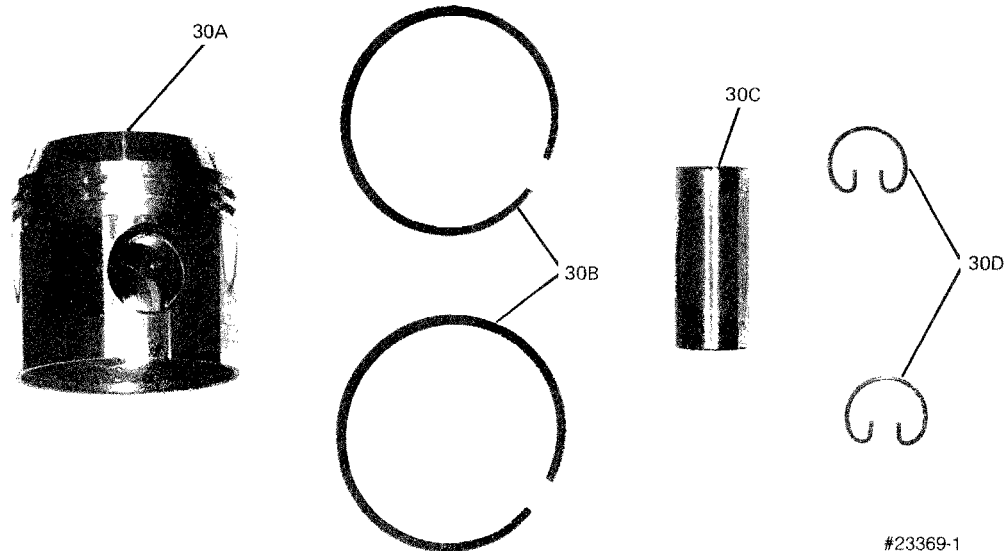

#23369-1

ITEM NO.	DESCRIPTION	PART NO.
③ 30	Piston Assembly Includes:	364-46757
30A	Piston, Bare	064-46538
30B	Ring, Piston (2 Req'd./Piston)	029-15175
30C	Pin, Piston	029-13090
30D	Retainer (2 Req'd.)	029-13091

FIG. 2 — PISTON ASSEMBLY

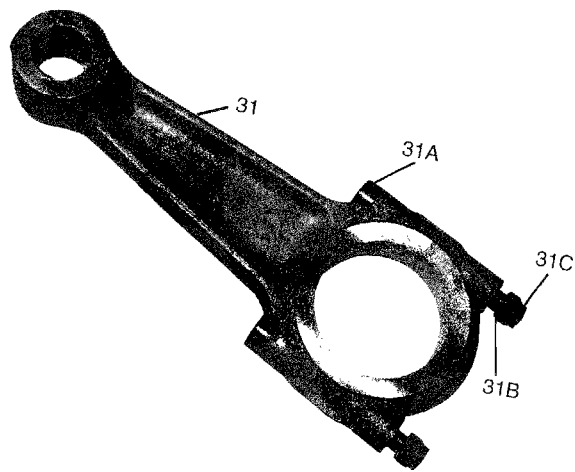

#10354

ITEM NO.	DESCRIPTION	PART NO.	
		"3" STROKE	"4" STROKE
CONNECTING ROD WITH THRU BOLTS & LOCK NUTS*			
③ 31	Rod, Connecting Ass'y.	664-21611	664-46679
31A	Bolt (2 Req'd.)	021-14392	021-14392
31B	Washer (10/Pk'g.)	221-01274-800	221-01274-800
31C	Nut (5/Pk'g.)	221-09932-800	221-09932-800

† SPECIAL NOTICE:
COMPRESSORS BUILT AFTER JULY, 1987 CAN HAVE THIS CONNECTING ROD, ALTHOUGH BOTH DESIGNS HAVE REMAINED IN PRODUCTION.

#23369-2

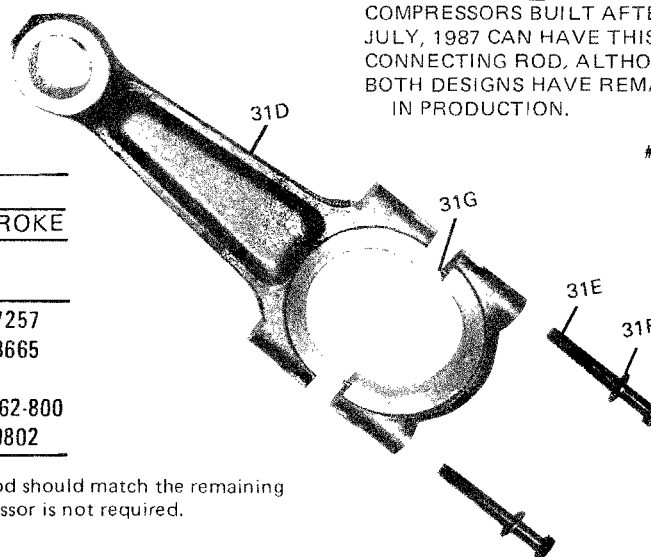

ITEM NO.	DESCRIPTION	PART NO.	
		"3" STROKE	"4" STROKE
CONNECTING ROD WITH STD. SCREWS & DOWEL PINS*†			
③ 31D	Rod, Connecting Ass'y.	364-47256	364-47257
31E	Screw Cap Hex (2 Req'd./Rod)	021-13665	021-13665
31F	Washer (10/Pk'g.)	221-01262-800	221-01262-800
31G	Pin Dowel (2 Req'd.)	029-19802	029-19802

*Complete connecting rods are interchangeable. Replacement rod should match the remaining rods in any one compressor, but matching styles in one compressor is not required.

FIG. 3 — CONNECTING ROD

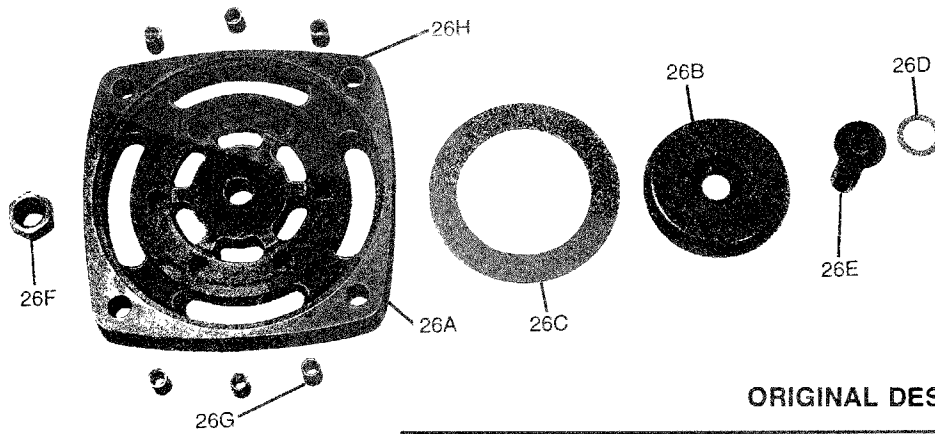

ORIGINAL DESIGN

#10358

ITEM NO.	DESCRIPTION	PART NO.
②26	Cage, Discharge Valve Assembly: Includes Items A thru G	664-42306
26A	Cage, Discharge Valve	064-43146
26B	Plate, Inner Valve	064-46281
26C	Valve, Discharge	064-43012
26D	Gasket	028-08386
26E	Screw (3/8 - 24 x 1-5/8")	021-13856
26F	Nut, Self-Locking (5/Pk'g.)	221-09932-800
26G	Spring (24/Pk'g. - 6 Springs Req'd. Per Valve Assembly)	229-13248-800
26H*	Bolt 3/8" x 2-1/2" (5/Pk'g. - 4 Bolts Req'd. Per Valve)	221-10037-800

*(Not shown) When installing new valve cage assembly, always order 4 of items 26H for each valve cage.

FIG. 4A — DISCHARGE VALVE CAGE ASSEMBLY (ORIGINAL DESIGN) (ALSO SEE TABLES 4 & 5, page 12)

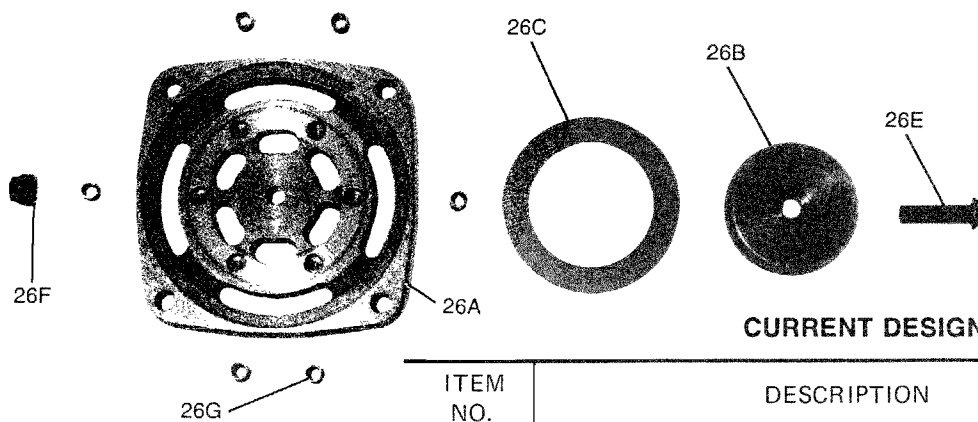

CURRENT DESIGN

#26644

ITEM NO.	DESCRIPTION	PART NO.
26	Cage, Discharge Valve Assembly: Includes Items A, B, C, E, F, G	
26A	Cage, Discharge Valve	064-43146
26B	Plate, Inner Valve	064-48032
26C	Valve, Discharge	064-43012
26E	Screw, Cap Bu	021-17649
26F	Nut, Hex Self	021-09932
26G	Spring, Hel C	028-13248
*	Drawing — Cage Discharge (Current Design)	064-48037

FIG. 4B — DISCHARGE VALVE CAGE ASSEMBLY (CURRENT DESIGN) (ALSO SEE TABLES 14 & 15, page 12)

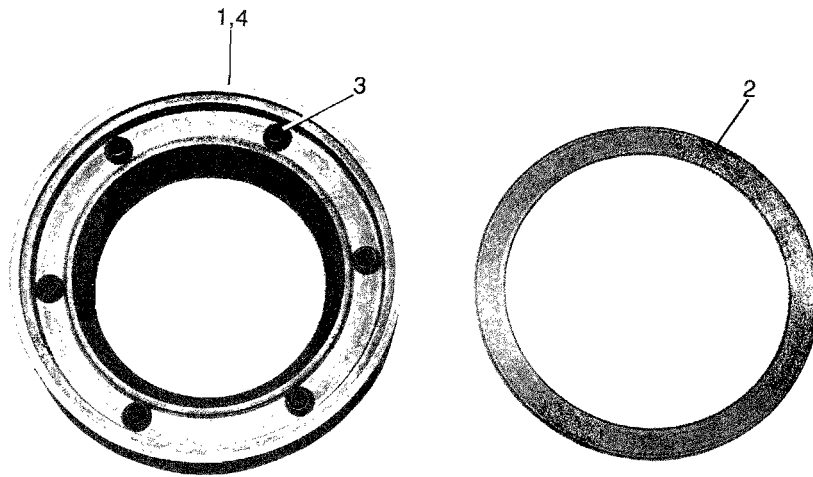

ITEM NO.	DESCRIPTION	PART NO.
③ 28	Plate, Suction Valve Ass'y. Includes:	664-42718
28A	Plate, Valve	064-42716
28B	Valve, Suction	064-43011
28C	Spring (24/Pk'g.—6 Springs Req'd Per Valve Ass'y.)	229-13813-800

FIG. 5 — SUCTION VALVE PLATE ASSEMBLY (ALSO SEE TABLES 4 & 5, PAGE 12)

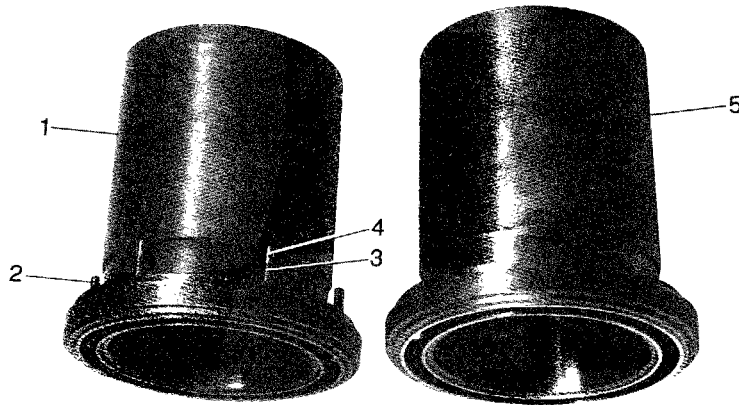

ITEM NO.	DESCRIPTION	PART NO.		
		4 Cyl.	6 Cyl.	8 Cyl.
CYLINDER SLEEVE — UNLOADING		● SEE FIGURE 10 FOR LOCATIONS		
③ 29 I	Sleeve, Cylinder Ass'y. (No. Req'd. See Fig. 10)	664-47224	664-47224	664-47224
29A	Sleeve, Cylinder	664-21667	664-21667	664-21667
29B	Pin, Lift (24/Pk'g.—6 Pins Req'd. Per Cyl. Ass'y.)	229-19841-800	229-19841-800	229-19841-800
29C	Spring (24/Pk'g.—6 Springs Req'd. Per Cyl. Ass'y.)	229-13487-800	229-13487-800	229-13487-800
29D	Ring, Retainer (12 Req'd. Per Cyl. Ass'y.)	029-09016	029-09016	029-09016
CYLINDER SLEEVE — NON-UNLOADING		○ SEE FIGURE 10 FOR LOCATIONS		
③ 29 II	Sleeve Cylinder (No. Req'd. See Fig. 10)	664-21667	664-21667	664-21667

FIG. 6 — CYLINDER SLEEVE ASSEMBLY

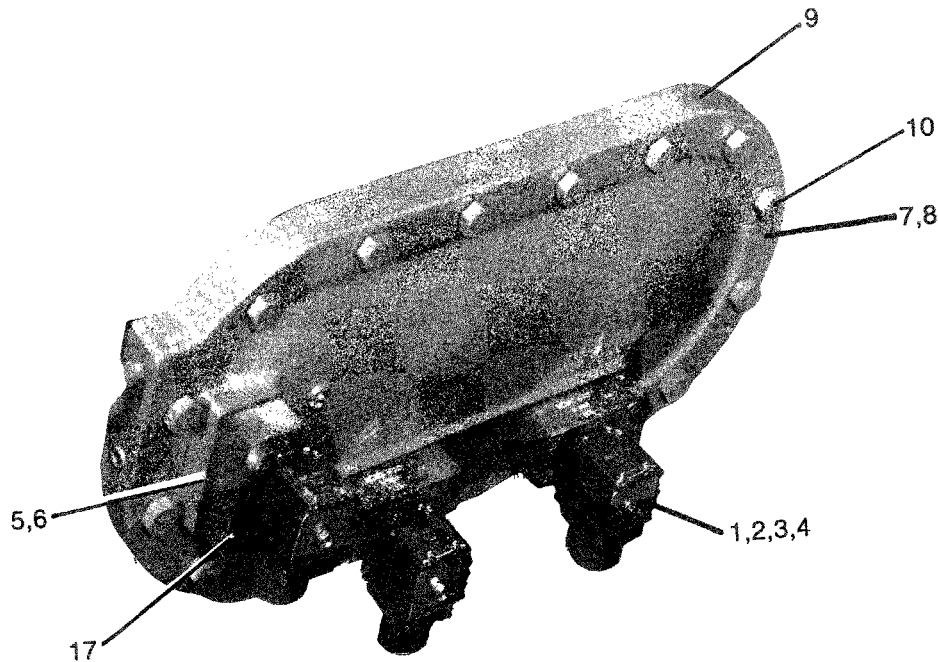

ITEM NO.	DESCRIPTION	PART NO.		
		1 SOL. UNLOADING	2 SOL. UNLOADING	3 SOL. UNLOADING
24 *	Cover, Handhole (for unloading)†	664-47226	664-47225	664-47222
Ⓢ 24A	Valve, Solenoid Less Coil Sporlan Product Engineering	025-26270-011 025-26270-012	025-26270-011 025-26270-012	025-26270-011 025-26270-012
Ⓢ 24B**	Coil for Item 24A			
	Sporlan	120V 240V	025-25146 025-26268	025-25146 025-26268
	Prod. Eng.	120V 240V	025-16572-005 025-16572-002	025-16572-005 025-16572-002
24C	Gasket, Sol. Valve to Cover	064-47327	064-47327	064-47327
24D	Screw, 1/4 20 UNC. - 2 AX 1-1/4 (5/Pk'g.) 1 Pk'g. Req'd./Valve	221-01392-800	221-01392-800	221-01392-800
24E	Plug, Pipe Soc. Hd. 1/8 NPT (Not Shown) No. Req'd.	023-01970 3	023-01970 5	023-01970 7

*Item 24 does not include Items 24A, 24B, 24C, 24D or 24E.

**Coils are not interchangeable i.e., Sporlan valves require Sporlan coils & Product Engineering valves require Product Engineering coils.

†See Fig. 11 for Crankcase Float Handhole Cover.

ITEM NO.	DESCRIPTION	PART NO.
25	Cover, Handhole (Plain) (Not Shown)	664-21645
25A†	Gasket, Handhole Cover to Compr. (Not Shown) No. Req'd. Per Compressor	064-21700 2
25B†	Screw Cap Hex. 7/16 - 14 x 1-3/4 (5/Pk'g.) 9 Pk'gs. Req'd. Per Compressor	221-01545-800

†These items are common to both types of handhole covers.

FIG. 7 — HANDHOLE COVERS

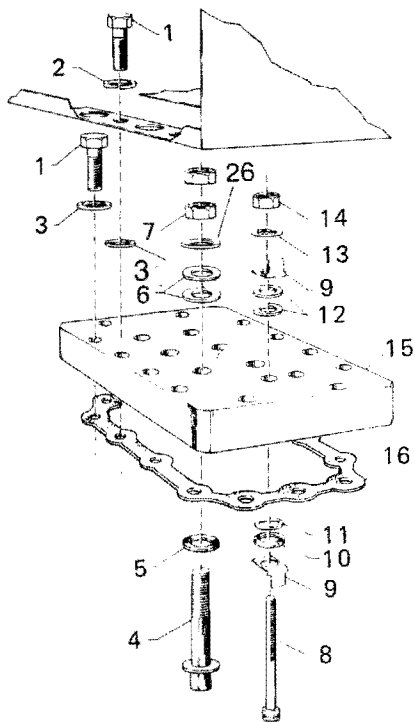

ITEM NO.	DESCRIPTION	PART NO.	
		STYLE E	STYLE F
1	Screw - 7/16 - 14 x 2 (14 Req'd.)	021-13198	021-13198
2	Lockwasher - 7/16 (10/Pk'g.)	221-01161-800	221-01161-800
3	Washer, Plain - 7/16 (10/Pk'g.)	221-14111-800	221-17270-800
4	Bolt, Terminal (6 Req'd.)	021-12696	021-12696
5	Gasket, Terminal Bolt (6 Req'd.)	064-36151	064-36151
6	Washer, Terminal Bolt (10/Pk'g.)	228-09410-800	228-09410-800
7	Nut, Hex (6/Pk'g.)	221-12724-800	221-12724-800
8	Screw, Overload Protector (5/Pk'g.)	221-14817-800	221-14817-800
9	Terminal, Overload (Style E - 4 Req'd. Style F - 8 Req'd.)	025-18650	025-18650
10	Washer, Plain (10/Pk'g.)	221-01240-800	221-01240-800
11	Seal, O-Ring (Style E - 2 Req'd. Style F - 4 Req'd.)	028-09347	028-09347
12	Washer, Terminal (10/Pk'g.)	228-09525-800	228-09525-800
13	Lockwasher (20/Pk'g.)	221-01133-800	221-01133-800
14	Nut, Hex (10/Pk'g.)	221-09991-800	221-09991-800
15	Block, Terminal	025-27801	025-19978
16	Gasket, Terminal Block	064-21839	064-21839
17	Spacer, Insulating (2 Req'd.)	064-47346	064-47346
18	Block, Term. Base, Flat (Style E - 13 Req'd. & Style F - 15 Req'd.)	025-20944	025-20944
19	Block, Term. End	025-20946	025-20946
20	Bar, Jumper*	064-47424	064-47424
21	Module, Motor Protector, 120V	-	025-27522
	Module, Motor Protector, 240V	-	025-28722
	Module, Motor Protector, 24V	-	025-29939
22	Box, Terminal	364-47342	364-47606
23	Cover, Terminal Box	064-46993	064-47459
24	Screw, Term. Box Cover	021-08197	021-13784
25	Lockwasher	-	021-01133
26	Washer, Plain	021-17646	021-17646

*Used on across-the-line start

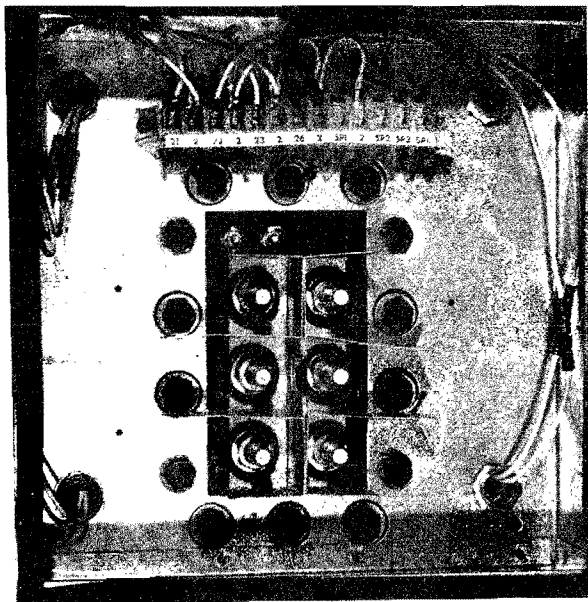

STYLE E

#23362

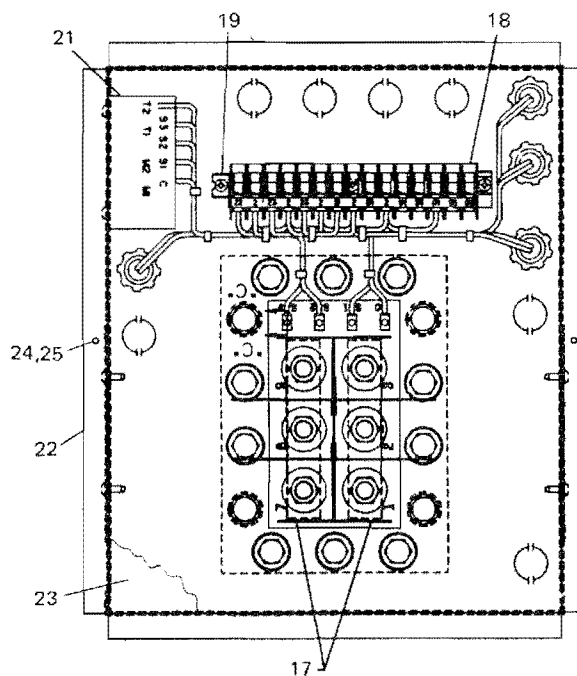

STYLE F

FIG. 8 - TERMINAL PLATE

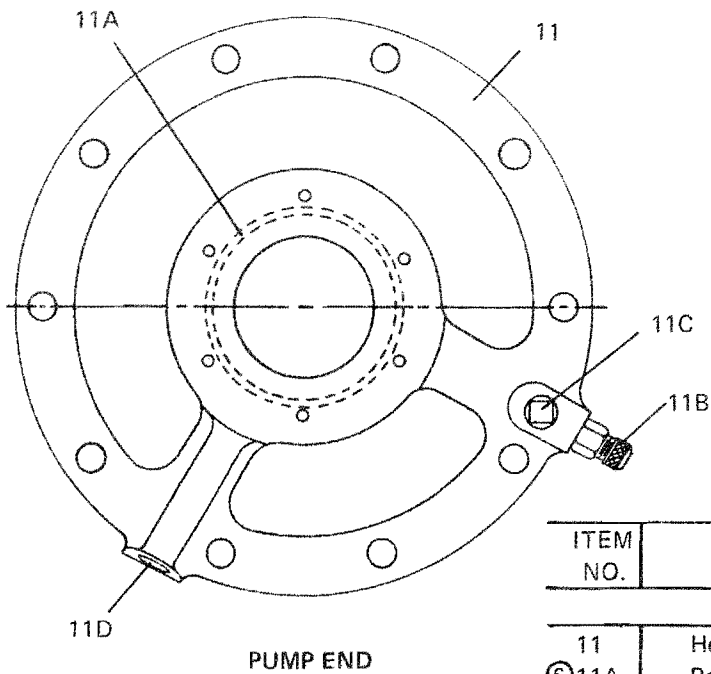

ITEM NO.	DESCRIPTION	PART NO.
BEARING HEAD – PUMP END		
11	Head, Bearing Ass'y Pump End	664-47337
⑤ 11A	Bearing, Crankshaft	029-11097
11B	Valve, Access	022-04521
11C	Plug, Pipe 1/4 - 18 Sq. HD.	023-01972
11D	Plug, Pipe 3/8 - 18 SCK.	023-04298
–	Head, Bearing, Pump End (Less Items A,B,C & D)	664-47193

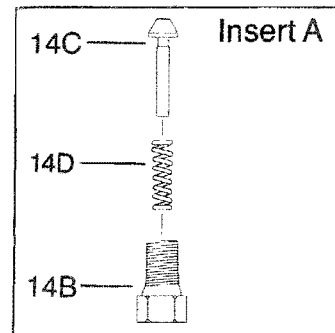
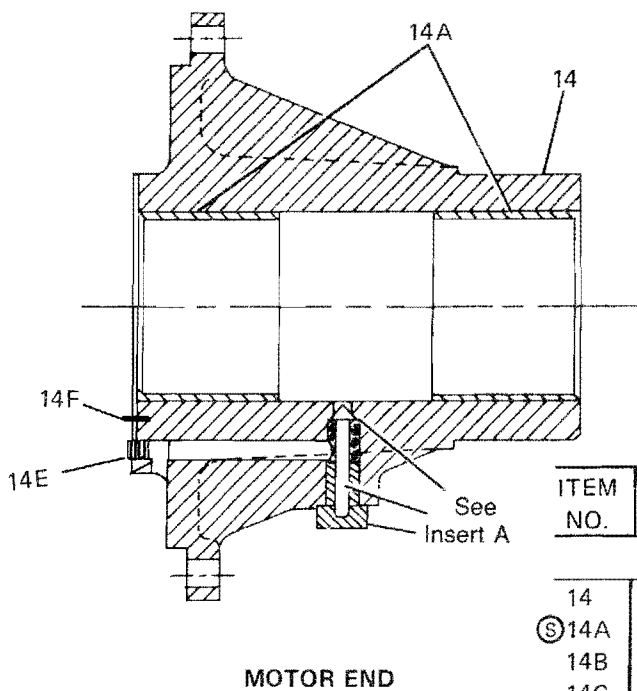

ITEM NO.	DESCRIPTION	PART NO.
BEARING HEAD – MOTOR END		
14	Head Bearing Ass'y, Motor End	664-47221
⑤ 14A	Bearing, Crankshaft (2 Req'd.)	029-11097
14B	Cap, Seal, Oil Relief Valve (see insert A)	065-06394
14C	Plunger, Oil Relief Valve (see insert A)	065-01331
14D	Spring, Helical, (see insert A)	029-06143
14E	Plug, Pipe 1/16 - 27 NPT	023-05366
14F	Pin, Roll 1/8 Dia. x 3/8 Lg.	029-05395
–	Head, Bearing, Motor End (Less Items A, B, C, D, E & F)	064-47220

FIG. 9 – HEAD BEARINGS

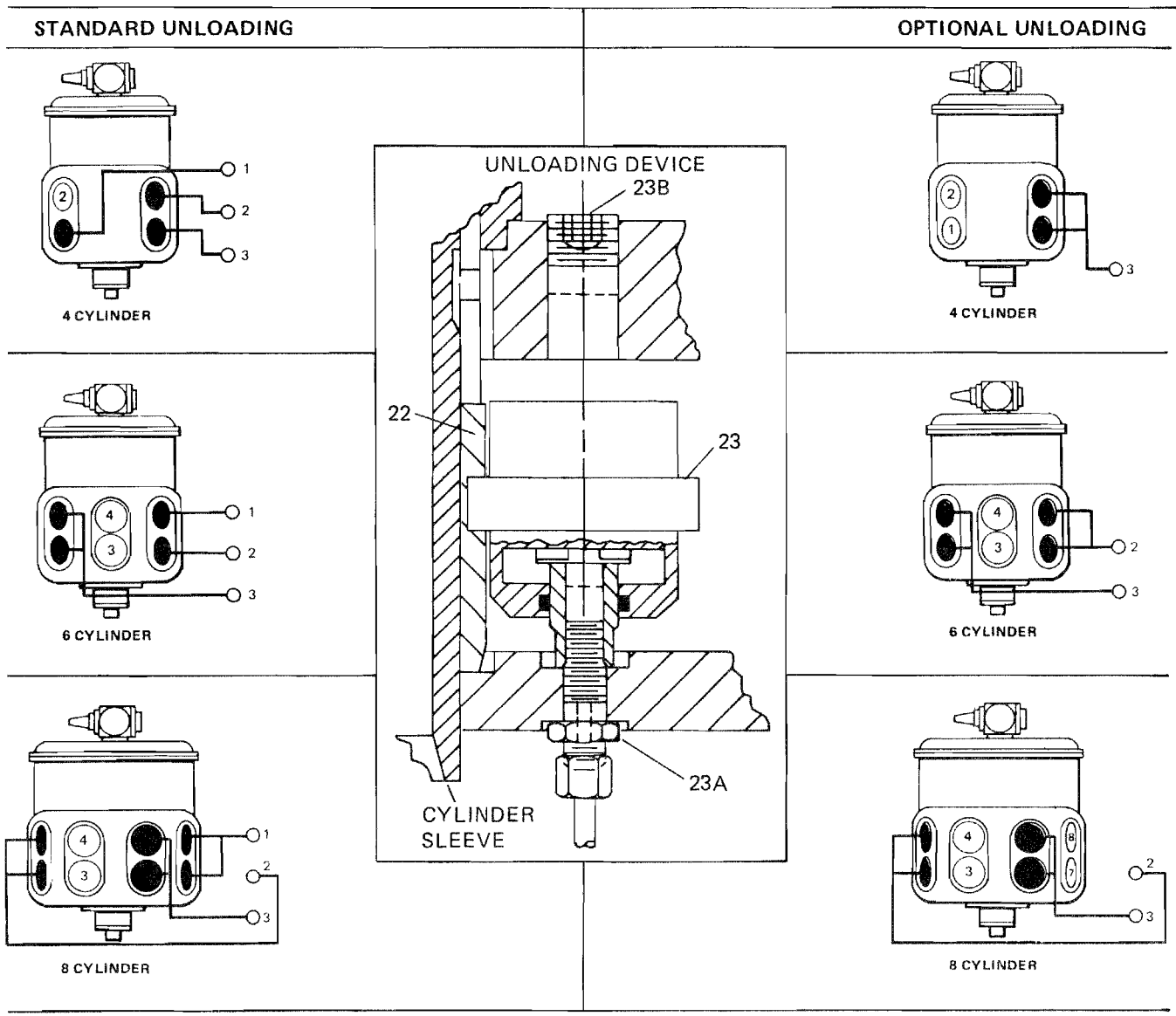

KEY

(1) (2)	CYLINDER NUMBERS	● UNLOADING CYLINDERS	○ PERMANENTLY LOADED CYLINDERS	○ 1 ○ 2 ○ 3	UNLOADER SOLENOID NUMBERS
------------	---------------------	--------------------------	-----------------------------------	-------------------	---------------------------------

TYPE UNLOADING	4 CYL. COMPRESSOR		6 CYL. COMPRESSOR		8 CYL. COMPRESSOR	
	QTY. OF UNLOADING CYLINDERS	CYLINDER LOCATION NUMBER	QTY. OF UNLOADING CYLINDERS	CYLINDER LOCATION NUMBER	QTY. OF UNLOADING CYLINDERS	CYLINDER LOCATION NUMBER
1 SOL	2 (OPT.)	3,4	—	—	—	—
2 SOL	—	—	4 (OPT.)	1,2,5,6	4 (OPT.)	1,2,5,6
3 SOL	3 (ST'D.)	1,3,4	4 (ST'D.)	1,2,5,6	6 (ST'D.)	1,2,5,6,7,8

ITEM NO.	DESCRIPTION	PART NO.
Ⓢ 22	Sleeve, Unloader	064-47195
Ⓢ 23	Device, Unloader	364-21681
Ⓢ 23A	Union, Unloader Device	023-05839
23B	Plug, Pipe 3/8 NPTE	023-04298

FIG. 10 — UNLOADING DEVICE

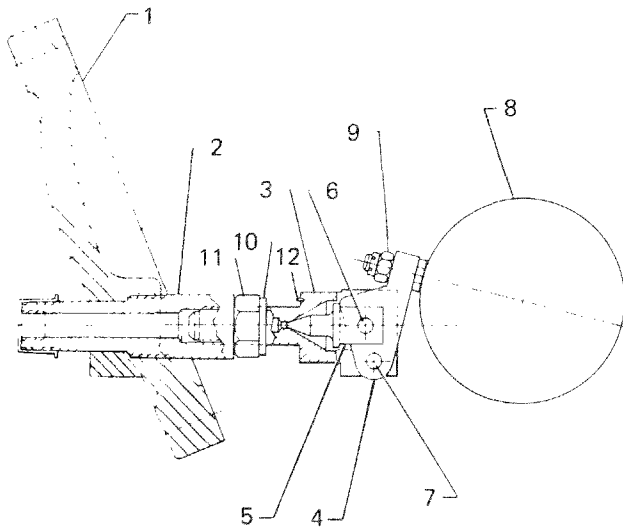

ITEM NO.	DESCRIPTION	PART NO.
	Crankcase Float Includes:	364-26809
1	Cover, Handhole	664-26808
2	Adapter	064-26807
3	Valve Body	064-45531
4	Lever, Float	068-04542
5	Valve, Float	068-04545
6	Pin, Valve	068-01594
7	Pin, Lever	065-02071
8	Ball, Float	022-00530
9	Nut-Hex Self-Locking (5/Pk'g.)	221-09610-800
10	Lockwasher	021-05273
11	Nut, Hex Jam (10/Pk'g.)	221-08073-800
12	Pin, Roll (5/Pk'g.)	229-08228-800

FIG. 11 — CRANKCASE FLOAT

TABLE 1 —REPLACEMENT MOTORS—STYLE E & F (ROTOR & STATOR)

VOLTAGES	VOLTAGE CODE	MOTOR SIZE CODE ³						
		M	N	P	Q	S	T	V
200-3-60	17	364-47924D001	364-47924D008	364-47924D015	364-47924D022	364-47924D029	—	—
230-3-60/190-3-50	28/59	364-47924D002	364-47924D009	364-47924D016	364-47924D023	364-47924D030	—	—
380-3-60	40	364-47924D003	364-47924D010	364-47924D017	364-47924D024	364-47924D031	364-47924D039	364-47924D047
460-3-60/380/415-3-50	46/50	364-47924D004	364-47924D011	364-47924D018	364-47924D025	364-47924D032	364-47924D040	364-47924D048
575-3-60/500-3-50	58/70	364-47924D005	364-47924D012	364-47924D019	364-47924D026	364-47924D033	364-47924D041	364-47924D049
220-3-50	63	364-47924D006	364-47924D013	364-47924D020	364-47924D027	364-47924D034	—	—
440-3-50	43	364-47924D007	364-47924D014	364-47924D021	364-47924D028	364-47924D035	364-47924D043	364-47924D051
346-3-50	64	364-47924D101	364-47924D102	364-47924D103	364-47924D104	364-47924D105	364-47924D106	364-47924D107
ITEM 45 ²		021-16819	021-16819	021-16819	021-16820	021-16820	021-16820	021-16820
No. Req'd.		4	4	4	4	4	4	4

¹As indicated by sixth digit of model number. Replacement motor must be same size as original. Rotors and stators are not available separately. Replacement motors include Item 4, Fig. 8, page 8.

²See Fig. 1 for description. To be ordered only if damaged. Reuse existing screws wherever possible.

³The unused protector leads should be cut-off in the area where they exit the bundle. They should be cut-off at different lengths (approx. 1/4" difference) to prevent the bare ends from touching one another. The remaining portion of the unused protector leads must then be ty-rapped rigidly to the stator coils to prevent the exposed ends from touching any other component.

**YORK REMANUFACTURED COMPRESSORS ARE AVAILABLE FROM THE YORK REMANUFACTURING FACILITY
IN WHEELING, IL. FOR PRICES AND/OR AVAILABILITY, CALL 1-800-537-9675 OR FAX 1-708-541-0943.
FOR AFTER HOURS EMERGENCY SERVICE, CALL 1-708-541-9466.**

TABLE 3 — SERVICE AIDS

Ⓢ GASKET KIT COMPRESSOR MODEL			Ⓢ VALVE RETAINING CLIP	BEARING REMOVAL TOOL Ⓢ	ROTOR Ⓢ MANDREL *	STATOR REMOVAL TOOL
4 Cyl.	6 Cyl.	8 Cyl.				
364-47452	364-47453	364-47454	064-37274	364-37260	364-37273	029-13597

*Screws into end of crankshaft to aid in removing and installing rotor.

TOP HEAD “VALVE REPLACEMENT” KITS & TOP HEAD “OVERHAUL” KITS

The price of the kits shown below is less than the total price of the individual parts. These kits provide a convenient, economical method of ordering replacement parts.

Each Top Head “Valve Replacement” kit listed in Table 4 contains the suction and discharge valves, springs, gaskets, screws and nuts that are recommended to be replaced when a valve replacement is required.

Each Top Head “Overhaul” Kit listed in Table 5 contains the suction valves, suction springs, suction valve plates, discharge valve cage assemblies, gaskets, bolts and lockwashers that are recommended to be replaced when a top head overhaul is necessary.

Each kit has all the recommended parts to service the valves located under one head for each compressor listed.

A threaded torque value table is included with each kit.

If servicing a complete compressor, order the quantities as indicated in the table.

Valve replacement should be done annually or every 5,000 hours of running time. Depending on application, all gaskets may not be required.

TABLE 4 — TOP HEAD “VALVE REPLACEMENT” KIT

Kit Part No.	Each Kit Contains	No. of Kits Req'd. Per Compressor		
		4 Cyl	6 Cyl	8 Cyl
364-47667-007	Suction Valve Discharge Valve Suction Valve Springs Discharge Valve Springs Top Head Gasket Discharge Manifold Gasket	2	3	4

TABLE 5 — TOP HEAD “OVERHAUL” KIT

Kit Part No.	Each Kit Contains	No. of Kits Req'd. Per Compressor		
		4 Cyl	6 Cyl	8 Cyl
364-47666-010	Suction Valve, Plate & Springs Discharge Valve Cage Assembly Top Head Gasket Discharge Manifold Gasket	2	3	4



P.O. Box 1592, York, Pennsylvania USA 17405-1592
Copyright © by York International Corporation 1996
FORM: 180.23-RP3 (194)
SUPERSEDES: 180.23-RP3 (693)

Subject to change without notice. Printed in USA
ALL RIGHTS RESERVED
FAH 3M 496 .60
CODES: SRC, RNP